

The Newbie's Guide to Using D-Star

How to get the most out of your new D-Star
transceiver

V1.0

Susan Mackay VK3ANZ

© 2009 Susan Mackay

Permission is granted to use this document in whole or part for non-commercial and personal use provided that no personal or commercial gain is obtained. For any commercial use, please contact the author at VK3ANZ@gmail.com to obtain the necessary permission as negotiated on a case-by-case basis.

My thanks to Ross VK3HBS, David VK3UR, and Richard VK3JFK for their proof-reading and valuable comments and contributions to this document.

Purpose of this booklet

This is the booklet I needed when I bought my first D-Star transceiver.

D-Star is sufficiently different to the standard analog FM means of communication to make it a rather frustrating experience if you don't go about it the right way.

You must read the manual¹ that came with the radio. It will tell you how to use the various features of the radio. Unfortunately the radio's manual told me EVERYTHING the radio can do, but not when to use a particular feature, or why. or even if using a feature was necessary.

Layout of the Booklet

To understand D-Star requires a bit of theory and a definition of terms, concepts and protocols that, by themselves, might not make much sense. We need to build on these later to provide a full understanding of the abilities and capabilities of the radio. We'll start with a few of the necessary foundations.

Read Section 1 (D-Star Basics); do not skip or skim read it. It doesn't matter if you think you know some of it already. Read and understand this section before you go on.

Section 2 (D-Star Usage Scenarios) takes a 'play as you read' approach to build up your knowledge and experience in bringing the various bits of information from the first section together. It starts with some basic uses of the D-Star network and builds up to more advanced configurations.

At the end, you will find several appendices that provide additional information. A reference is made where an appendix augments that main text².

Strangely enough, the use of D-Star radios for simplex communications is relegated to an appendix. This is not because simplex is not that good or is a 'poor cousin' but because the real power of D-Star is its ability to use the internationally linked repeater network. Unfortunately with real power comes real complexity and confusion, if you are not careful and methodical in your approach.

I have deliberately been repetitive in this document, so that after reading through the whole thing once, you can read individual sections for reference.

OK, let's get started.....

¹ See Appendix 2

² See footnote 1 for an example

Section 1

D-Star Basics

Introduction

Firstly, D-Star is a technical protocol, not a product! The D-Star protocol is publicly available and is non-proprietary. At the moment, Icom make a number of transceivers that use the D-Star protocol and other manufacturers may well follow in the future. There are also several amateur-driven projects underway to allow people to build their own equipment that will conform to the D-Star protocol, and the DV-Dongle is a commercial product that (sort of) fits into this concept.

I will not get into the technical details of the protocol itself; if you want to do that then there are a number of web sites and discussion groups that will guide you as to where to find the information you need.

Rather, the approach here is biased to how to use D-Star as it is embodied within various radios.

Guidelines for using D-Star

There are several guidelines that you are expected to follow when you use the D-Star repeater network. These are above and beyond those specified by the various Amateur Radio guidelines and Government regulations established within a country or geographic region.

The D-Star guidelines are:

- Always listen for at least 10 seconds before you transmit
- Take note of the information on the display that the local repeater is sending to you immediately after you finish transmitting
- Make sure your transceiver is correctly set up with the (up to) 4 call sign values
- Leave at least a 4 second gap between overs
- Limit an over to less than 3 minutes (this is enforced by most D-Star repeaters which will drop your signal after 3 minutes)
- When establishing a contact, remember to set all of the necessary call signs (explained later in this document).
- ALWAYS make sure that your transceiver³ is correctly reset after you have finished your QSO

These may not make a lot of sense right now, but they will as we go through how the D-Star network operates and how we use it to make a QSO.

³ This may also apply to any on-going repeater configuration that you have established. However, such configurations are not covered in this document.

D-Star Repeater Call Sign Structure

Amateur radio call signs are up to 7 characters long (such as VK3AA, VK3MMM or VK3FZZZ⁴). Australian repeaters are also assigned call signs such as VK3RWN⁵.

As we will see shortly, D-Star repeaters also need a reference to the various ports they have. Each port has a single letter assigned to it which is always added in the **8th position** of the call sign. That means that there could be spaces within a repeater port call sign.

For example, port C on the VK3RWN repeater has the call sign “VK3RWN△C”. (Throughout this document I have used the ‘△’ character to visually indicate a space within a call sign).

D-Star call signs are up to 8 characters long. The general structure of a call sign used in the D-Star network is the basic user or repeater call sign in the first (up to) 6 or 7 places, and any special command or port indicator is in the 8th position.

If the call sign is less than 8 characters (e.g. VK3ANZ is only 6 characters) and no port or command letter is needed, then you only need to enter the call sign. (The D-Star radios and most computer programs will add trailing spaces to make the call signs always 8 characters long; however you don’t need to add the trailing spaces yourself).

D-Star uses the 8th character position to identify a repeater port (see later), call sign variants (see the section on registering your call sign) or specify a command to the network. In such cases, when the call sign is 6 or fewer characters long, it is **very important** that you put spaces after the call sign so that the special character occurs in the 8th character position.

Some examples are:

Basic Call Sign	D-Star Call Sign	Comment
VK3ANZ	VK3ANZ	No padding needed
VK3ANZ Mobile	VK3ANZ△M	The ‘M’ must in column 8 so add padding
VK3RWN port C	VK3RWN△C	
VK9ZZ port C	VK9ZZ△△C	Short call signs need more padding

Throughout this document, I’ve not shown the trailing spaces where they are not required. However, I have shown the spaces when they exist between the call sign and the 8th character.

⁴ My apologies to anyone who has these actual call signs - I’m just trying to make a point, not be specific about any call sign

⁵ Other countries have their own schemes to name repeaters.

Analog Repeater Structure

When you use an analog repeater, you set the receive frequency (the frequency the repeater will transmit on) and then applying an offset to come up with your transmit frequency (the frequency the repeater will receive on). To use the repeater, you just transmit⁶, the repeater picks up the signal and re-broadcasts it on its output frequency.

Normally the transmit and receive frequencies are within the same band and normally have a consistent offset between them (600kHz in the 2m band, 5MHz in the 70cm band and so on).

However, there are some places where the repeaters are linked together either so that there is greater geographic coverage or so that there are cross-band links. An example of the later is the VK3RHF repeater that spans the 10m, 6m, 70cm and 23cm bands so transmitting on the input frequency of one will result in a transmission on all of the output frequencies of the others. In New Zealand, they have a 'national link' where any signal received on one repeater is simultaneously broadcast on all others throughout the country.

D-Star Repeater Structure

A D-Star repeater comprise (up to) 5 connections, grouped as follows:

- RF voice ports used to receive and transmit voice communications with transceivers
- RF data ports used to receive and transmit data with transceivers
- network gateways that connect a repeater to the rest of the D-Star network

Not all repeaters have all ports but most repeaters have at least one RF port and a network gateway.

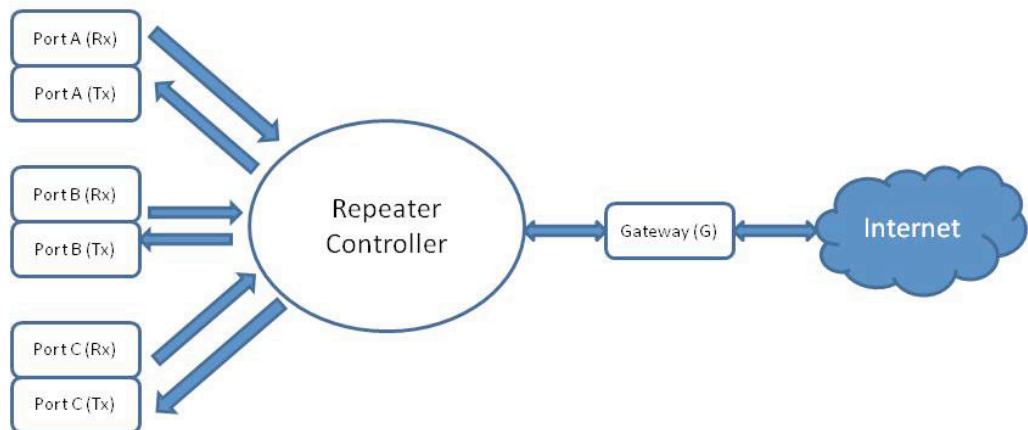

This figure shows 3 RF voice ports (labelled A, B and C - see below) and the gateway connecting the repeater controller (which connects all of the repeater ports together) to the Internet which is used to carry the D-Star network. The figure does not show a data port

⁶ Some repeaters require a CTCSS access tone.

but (logically) it operates the in the same way as the other RF ports but only carries data streams that are not intended to converted to voice.

Port labeling and function

Each RF port on the left of the above figure represents the two parts of an ordinary RF repeater - the receiver and transmitter. Each of these ports operates in a different frequency band with a common labeling protocol being ⁷:

- the 23cm RF transceiver is Port A
- the 70cm RF transceiver is Port B
- the 2m RF transceiver is Port C

On the right of the above diagram is the gateway between the repeater and the internet⁸.

If a RF data port is available it is always in the 23cm band due to the bandwidth requirements of sending data at high speeds.

Each repeater will have a configuration that suits the intended purposes as established by the repeaters operators. When they publish the repeaters frequencies, they will also specify the port labeling they have adopted.

Repeater Controller's function

Each repeater has a controller that coordinates the activities of the ports.

When you set the various call signs in your radio's Destination, Originator, Repeater1 and Repeater2 call sign fields (see below), it is the repeater controller of your local repeater that interprets these and performs the necessary operations to send your signal to the correct place in the D-Star network⁹.

When you press the PTT button of your D-Star radio, your voice is digitally encoded and is transmitted together with other digital information. A repeater port receiver picks up this RF digital data stream and passes it directly to the repeater controller.

The repeater controller receives data streams from each of the port receivers and (possibly multiple data streams) from the Internet gateway. Its main function is to interpret parts of the data streams (specifically the various call signs which we will talk about next) to see where they should be passed on to.

One of the repeater controller's critical tasks is to make sure that an RF transmitter only ever receives one stream of data at a time. Therefore the controller acts as an arbitrator

⁷ While this is the general labeling scheme used in Australia, it is possible that the RF port on any band be given any letter identifier, and even possible for there to be several RF ports in the same band. If you are using an overseas repeater, make sure that you understand the port labeling scheme used if this is important.

⁸ Just to be clear, D-Star uses the Internet as a transport mechanism to allow it to connect the various repeater and reflectors together. D-Star does not provide open access to the Internet

⁹ This statement is not quite technically correct in that the controller connects the RF ports together and also interacts with a separate gateway controller which performs the necessary operations to link the repeater to the outside world. However what I've said is close enough to understand what is going on.

and will allow the first data stream for an RF transmitter to pass, but will reject any other that is received while the first one is going.

A key concept to understand is that you use the D-Star network by asking the *local* repeater controller¹⁰ to make the various connections for you.

There are two types of connections that can be made, called “routing” and “linking”. Each style has its strengths and weaknesses which are discussed in the following sections. Which you use will depend on the circumstances at the time.

“Routing” connections are established for you by the controller when you press the PTT button, and are removed when you release it. Each person who participates in the conversation must set up their radios correctly and keep the correct settings for every transmission they make.

On the other hand, “linking” connections are established when you send special commands to the repeater controller, and they are maintained by the D-Star network until you send a corresponding command to remove them (or they time out after a period of inactivity).

The majority of the descriptions in Section 2 are “routing” connections and they are named as such.

D-Star Radio Call Sign Usage

A D-Star radio requires up to 4 call sign fields to be entered and manipulated as you use the device. There are a number of names and abbreviations used in various radios as to what these call signs are called. In this document I’m going to use the following names for the call sign fields:

- Originator - this is the call sign you are using
- Repeater1 - the call sign of the repeater port you use to access the **local** repeater
- Repeater2 - the call sign of the repeater port you use to leave the **local** repeater
- Destination - this is the call sign of the person, group or repeater you want to talk to

These are **not** the same names as you will see on your radio. Believe me, you can really get yourself confused when using names such as “My Call” and “Your Call”.

To make matters worse, different models of commercial radios use different abbreviations for these call sign fields. You can look in Appendix 1 to see a table of how these terms are used in various radios and how they relate to the names I’m using here.

I’ll briefly mention what each of these do.

Originator’s Call Sign

The radio regulations say that we have to give our call signs at the beginning and end of a QSO (and sometimes during a long over). Using D-Star does not change that, but it also

¹⁰ Technically speaking a D-Star repeater contains a controller for the RF side of things and a separate gateway controller. Each runs different software but they interact very closely with each other. In this document I use the term “controller” loosely to mean both the repeater controller and the gateway controller. As far as using the repeater is concerned they almost always appear to be the same.

sends out this and all other call signs in digital form when we start transmitting. Think of this as an automatic “this is me” signal.

Also, the D-Star network provides ways for users to manage the connections that can be made through the repeater’s controller (more on that later). However the controller needs to know who you are. Therefore you can think of the Originators call sign as your electronic identity (ID) into the system. For this to happen, you will need to register your call sign(s) with the D-Star network. If you look on the web pages associated with your local repeater or amateur radio group, they normally show you how the registration process works. (You only need to register once for D-Star international network-wide access. However you need to use the same web site for any updates so it pays to choose one that is close by for convenience). In Australia, information can be found at www.dstar.org.au which also contains links to the registration page.

Actually it goes beyond that. You might have several D-Star radios (say, one in the shack, one in the car and a “DV Dongle”¹¹ that you use on business trips). Because your call sign does not use all 8 spaces available, you are able to use the 8th position to indicate which radio you are using and for what purpose. Again there are protocols involved here (such as ‘M’ for mobile, ‘P’ for portable, space for your home shack) but the registration process will guide you as to what to use.

You can register up to 8 call signs. Note that you are identified by the call signs you register. There is nothing to stop you having several call signs loaded into the memory of a radio and then switch between them when you need to. However, the system identifies you by your call sign, not the radio it is stored in. Further, when you use “call sign routing”, D-Star uses the entire call sign (including any additional letter) to locate the last repeater where the call sign was used. This can lead to confusion and the additional letters on your call sign should be used with caution.

It is recommended that you only use your base call sign for D-Star unless you specifically require separate identification (by others) of different radios at the same time.

Repeater1 and Repeater2 Call Signs

These fields tell the local repeater how you want to enter (Repeater1) and exit (Repeater2) the local repeater.

Strangely, if you want your transmission to be sent to another repeater, you don’t use the Repeater2 field to specify that repeater. Rather the Repeater2 field is used to specify the port used to leave the local repeater. We’ll get to the details later on.

However the important thing to remember is that the “repeater” being referred to by these two call sign fields is the one that **you** are interacting with locally, not some other remote repeater.

Destination Call Sign

This field defines who or where you want to talk to. The Destination call sign is the real work horse of the 4 fields.

¹¹ A “DV Dongle” is a separate product you can buy to let you get access to the D-Star network through a computer and broadband Internet connection. By the way, the “DV” part stands for “Digital Voice” and is used to distinguish between voice and “Digital Data” (DD) uses of the D-Star network. More on DD later.

It is used to specify that you want to:

- talk locally,
- to a specific call sign wherever it is in the world,
- to a specific repeater
- to a named group of repeaters.

It is also used to establish and break on-going “linking” connections between repeaters and reflectors.

Enough - let's see how to use the radio.

Section 2

D-Star Usage Scenarios

Introductory Note

This section discusses how to set up your radio in various configurations.

For the communication to succeed, the radio will need to have the frequency set correctly and may well need to have the duplex setting and offset, tone access values and other things set as well. I'm going to assume that you know how to do these as they are part of the normal operation of your radio.

Here I'll only talk about the D-Star specific setup options.

Much of the following discussion is based on one person making a call either to a specific person, location, or to CQ, with one person responding. However, you need to keep in mind that there could be many people who want to join in the conversation. The examples illustrate the correct set-up of a radio and do not imply that they limit the conversation to only between 2 people.

Local Repeater, Same Band

Let's look at the simplest case - to transmit on (say) the 2m port input frequency and have the signal rebroadcast on the same band. This is the default way each port is set up - it will (almost) always rebroadcast what it receives on an RF port back via that same port.

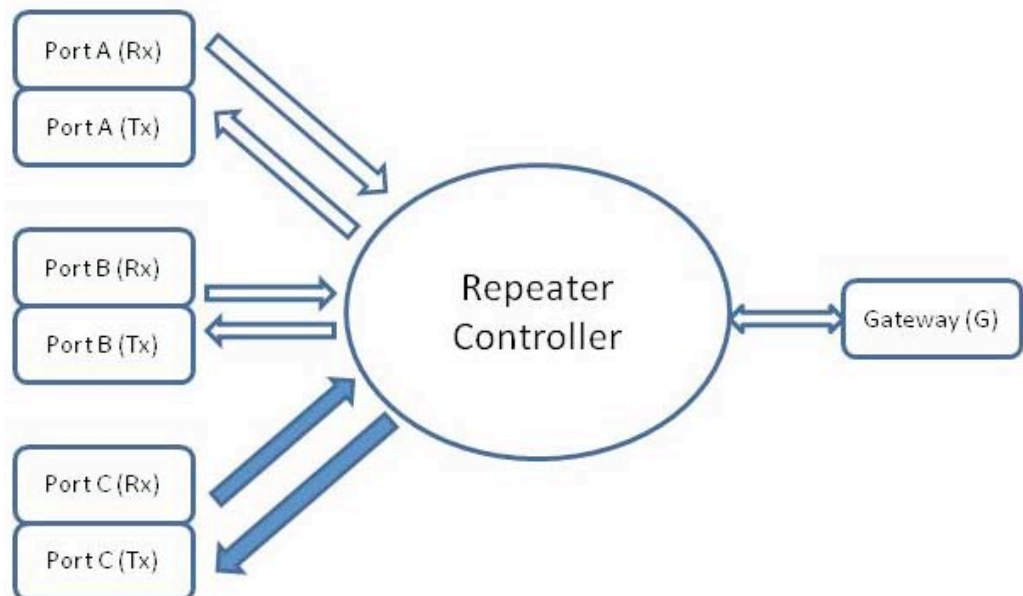

Making the contact

Even in this simple case I need to make sure that my radio is set up correctly.

Call Sign Field	Example Entry
Originator	VK3ANZ
Repeater1	VK3RWN△C
Repeater2	VK3RWN△C or VK3RWN△G or NOT△USE*
Destination	CQCQCQ

It is best to set the Originator call sign field to my call sign that I use most commonly right from the start. This field is not changed very often and most people never change this at all.

In this scenario, I don't need to have my call sign registered as I'm not using the D-Star network. However, because I generally don't need to change this field's call sign, it pays to use one of the call signs I have registered so as to avoid problems later on.

Next I set the Repeater1 call sign field to the name of the local repeater port that I will be transmitting to. It is important to get this right, because the repeater will reject your transmission if this is not set correctly.

Then I set the Repeater2 field call sign to one of the local output repeater port (in this scenario, that's the same one as I use for Repeater1), the repeaters gateway call sign (see later). Some radios have a "Not Used" value that they can put in here for this purpose. I prefer to use the Repeater2 field the same way as it is used for all other usage scenarios that involve the repeater, so I set it to the repeaters gateway¹².

In this situation, the Destination call sign field should be set to "CQCQCQ" as we are not trying to find any particular person or any other repeater in the network.

Now when I press the PTT button, my radio will transmit this information to the local repeater along with my digitized voice.

In keeping with the radio regulations and the D-Star usage guidelines given above I should now say:

"This is VK3ANZ calling CQ on VK3RWN Port C"

Answering the contact

(By the way, this section applies to responding to any call in any situation.)

For now, let's imagine that I'm someone else - say VK3AAA - and I want to monitor my local repeater (say VK3RWN Port C). To do this I need to firstly set my radio to the correct repeater port output frequency. Then I should set the call sign fields in preparation for any responses I might want to make. Therefore I put my own call sign the Originator call sign

¹² A further problem with not setting the Repeater2 field is that DV Dongle users will not hear your RF transmissions. Unless you are using the repeater in cross-band, I recommend that you set the Repeater2 field to the local repeaters gateway call sign for this and other reasons that will become clear later on.

and, because I'm listening on, and likely to transmit to, VK3RWN Port C, that is what I should put into the Repeater1 call sign field.

At this point I hear VK3ANZ calling on the local repeater port and I would like to respond. VK3ANZ has said their call sign and the repeater port they are transmitting to so I now have all of the information I need to return the contact.

Option 1 - Manual configuration

I listen to what the other person has said and set up my radio accordingly. The caller has told me that they are also listening on VK3RWN port C and so I have a choice as to how I set the Repeater2 call sign field. Because they are using the same repeater as I am, I don't need to set the Repeater2 field to anything (for the same reasons as described in the 'Making the contact' section above) or I could set it to the repeater's gateway (preferred as it generally involves changing fewer call sign fields) or to the same as the Repeater1 field.

They have also given me their call sign. If I want to I can enter their call sign (plus any necessary spaces and call sign variant letter) into the Destination call sign field. However, because I have already set up the Repeater2 field with the repeater port that they used, I can also simply put "CQCQCQ△△" as the destination call sign.

Call Sign Field	Example Entry
Originator	VK3AAA
Repeater1	VK3RWN△C
Repeater2	VK3RWN△G or VK3RWN△C or NOT△USE*
Destination	CQCQCQ

Option 2 - 'One Touch' configuration

This method relies on the digital information that the repeater sends out along with each transmission. The call sign of the person who sent the last transmission as well as the Repeater1 and Repeater2 call sign values are automatically sent at the start of each transmission from the repeater port.

Many commercial radios have the ability to capture this information and store the values from the last few transmissions. They also have the ability to retrieve this information and to set the call sign fields correctly for me. This is often referred to as a "one touch" or "one button" reply function. By pressing the appropriate button¹³ you can have the Repeater1, Repeater2 and Destination call sign fields set up automatically. (The Originator call sign field remains unaltered by this function at whatever I have it set to).

¹³ This is yet another area where radios differ. Some radios require that you press the "one touch" button while the other party is still transmitting while other radios save this information and allow you to press the button anytime before you receive another transmission. Yet others allow you to retrieve any of the last few received call signs.

Call Sign Field	Example Entry
Originator	VK3AAA
Repeater1	VK3RWN△C
Repeater2	VK3RWN△C
Destination	VK3ANZ

Please note that this does not always work on some radios, especially those that have a 'power save' feature as these radios can rapidly turn the power on and off to the receiver and so cut down on the overall power consumption. This rapid switching stops as soon as a signal is detected. The time the radio spends off is negligible in comparison to the time it takes to listen to even a brief call by an operator. Unfortunately, if the radio is off when a transmission begins, the radio will miss the very first part which contains the information needed for the "one touch replay" function. If this happens, then you must set the various D-Star call sign fields manually as described above.

Once the radio is correctly configured, I can make my response to the original caller. Because we both now have our radios set up, we can continue our conversation back and forth without further configuration of the D-Star call sign fields.

Finishing the contact

After the contact is over, you should get into the habit of resetting the Destination call sign field to "CQCQCQ". On most radios this simply involves pressing a button.

Usage issues

Why should you bother resetting the configuration after your QSO? The radio configuration described in the "Making the contact" subsection above already has the Destination field set correctly so there is no problem. However the configuration described in the "Answering the contact" sub-section may well have the other persons' call sign in this field. This is almost the necessary set-up for the D-Star network to perform "Call Sign Routing" (described a bit later) and your transmission could well suddenly come out somewhere else in the network.

Therefore it is a good habit to get into to **always** reset the Destination call sign field to "CQCQCQ" when you have finished.

Status Messages

Whenever you finish a transmission to a repeater port, the repeater controller will send back a very brief status message to you. The status message is actually telling you whether your transmission was received (there will be no status message if it wasn't), and how far it got through the network to its destination. In this scenario, the destination is very close by, it still might not have got through.

This is because the repeater controller might have received another transmission that was destined for the same output port as yours which arrived just ahead of yours. It is quite possible that the other transmission arrived between when you pressed the PTT button and your rig turned off the speaker, and when it started sending your transmission.

If the status message refers to the same port that you are sending to (i.e whatever is specified in your Repeater1 call sign field), then you will know that your transmission was successfully broadcast. If not, then it will give you the call sign of the part of the network where the failure occurred. In this scenario that means you will get back a message “**UR? VK3RWN△C**”.

If your transmission is not successful at all, you will get “**RPT?**”.

Different radios may display this information differently and the manuals for some radios do not cover the display of this information at all. You will need to see what is displayed on your radio when you have completed a successful transmission and understand that anything else might indicate some problem along the way.

Local Repeater, Cross Band

In this scenario, you are transmitting to one RF port on the local repeater and also having your transmission routed to another port on the same repeater. This provides a useful way of accessing a frequency band that (for example) your radio does not have. However, you should also be aware that it ties up two of the RF ports on the repeater for the one QSO and so reduces the availability of the repeater to other users. Therefore I advise that you use this style of operation with due consideration for other users.

Making the contact

Now let's say I want to transmit to the 2m C port and also have the signal come out on the 70cm B port; i.e. cross-band the local repeater.

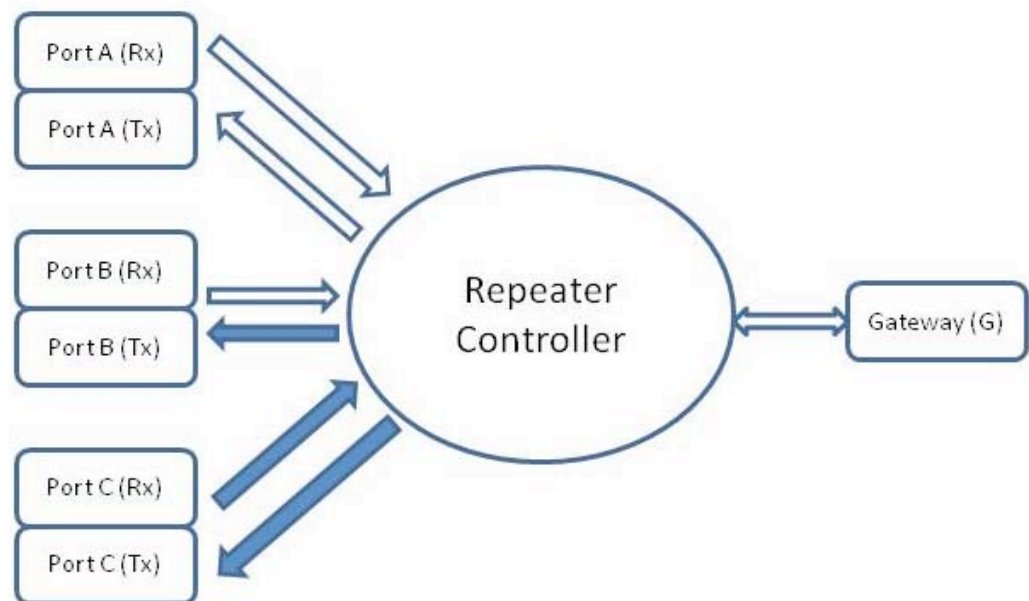

To do this I have to tell the local repeater that I want to send my signal within the repeater from the C port to the B port. I do this by setting the Repeater1 call sign to the C port of the local repeater, and the 'Repeater2' call sign to the call sign of the B port.

I need to set the Originator call sign field to my call sign and, because I'm just wanting to make a general call, I set the Destination call sign field to "CQCQCQ".

Call Sign Field	Example Entry
Originator	VK3ANZ
Repeater1	VK3RWN△C
Repeater2	VK3RWN△B
Destination	CQCQCQ

This is very similar to the "same band" scenario discussed above, but in this case the Repeater2 call sign field **must** be set correctly (before I could leave it "not used" or set it to the call sign of the local repeater's gateway).

With the radio configured, I can now make my call:

"This is VK3ANZ on repeater VK3RWN Port C calling CQ on VK3RWN Port B"

Answering a contact

Now imagine that I am VK3AAA and I've been listening on VK3RWN Port B when I hear VK3ANZ make their call. I want to respond so I need to set up my radio appropriately.

This is very similar to the situation described in "Making the contact" in that I need to set up the correct Repeater1 and Repeater2 call sign fields so that my transmission will be routed back to wherever they are listening. I can also set up the Destination call sign field with either "CQCQCQ" or the callers call sign.

As before, I can do this in 2 ways - automatically by pressing the appropriate "one touch reply" function button on my radio, or manually based on the information they have just provided to me verbally. If I use the "one touch reply" method, then all of the Repeater1, Repeater 2 and Destination call sign fields will be set for me. On the other hand, if I use the manual method, then I know that the Repeater1 field should be set to the repeater port that I was listening to and so I need to set the Repeater2 and Destination call sign fields based on what I heard the caller say.

As always, my Originator call sign field is my own call sign.

Call Sign Field	Example Entry
Originator	VK3AAA
Repeater1	VK3RWN△B
Repeater2	VK3RWN△C
Destination	VK3ANZ or CQCQCQ

Now both the original caller and I have our radios set up properly, we can talk away to each other.

Finishing the call

As before, when you have finished your QSO, you should reset the Destination call sign field to "CQCQCQ".

However, the difference to the "same band" scenario described above is that now you have your Repeater2 call sign field set to the other port. If you start transmitting without making any changes to this field, then you will also have your signal sent out over both ports. This implies that you should reset the Repeater2 call sign field to one of "not used", the local repeater's gateway call sign (preferred) or the same as the Repeater1 call sign field.

Most commercial radios have lots of memories (typically many hundreds) and so it is not unreasonable to have one memory set up so that it has this default 'reset' configuration. Further, it should be easily set so having a memory slot such as number 0 set up this way would be useful.

Usage issues

The situation just described brings up a couple of points about the use of D-Star that are not (usually) found in the operation of other repeaters.

Normally, if analog repeaters are linked together, then you can hear any transmission being picked up by any repeater on all of the others. Therefore it is easy to tell if the repeater is in use so that you don't double with someone else.

However, the connection between the port you use to access the repeater (Repeater1) and the port you use to leave the repeater (Repeater2) is only established for the duration of your single transmission. Someone could well be talking away on (say) Port B when you, on Port C try to make a cross-band connection. You will have no idea that they are talking on Port B.

Yes, I know that in this case I could say to listen on the other band, but what if I don't have a radio capable of receiving the other band (my IC-91AD can't access the 23cm band). And we will shortly see usage scenarios where the other repeater can be anywhere else in the world.

So, how do you get around this?

The D-Star system is set up so that a port will only accept a single data stream at a time. This is managed by the Repeater Controller and applies equally to transmissions received via an RF port's receiver and data streams from remote repeater sites.

If you try to route a transmission between ports and the destination port is in use, your call will not go through.

OK, but how do you know if your transmission has not gone through to its intended destination? The connection is only half-duplex so you can't necessarily hear yourself talking.

Well, when you finish transmitting to a port, the repeater will send back a short message to you; in effect it calls you back for a split second to send some call sign information.

If the returned message is “**UR? {callsign}**” where {callsign} is that of the repeater port you have specified as Repeater1, then you know that you call when through. Anything else means that the call was stopped at the point in the route of the returned {callsign}. Therefore, in this case, that means that you would be sent back the call sign of the Repeater2 port that you were trying to talk to but was busy.

Now you can see why I said in the Usage Guidelines section that you need take note of the information the local repeater is sending back to you. It is actually telling you if your call succeeded.

This also has something to do with why you should listen before you transmit, why your over should be short, and with at least a 4 second gap before you respond. Just because you have just been listening to someone on another repeater port, doesn't mean that the repeater will hold the connection open for your response. Remember, the routing occurs for each individual transmission only. Someone else may have 'got in' before you on the other port and be transmitting - but of course you won't be aware of that and so you start talking away, only to have the repeater not route your transmission. It would be a pity to be talking for a couple of minutes (short overs remember!) only to find that no one has been listening!

Call Sign Routing

Now we are starting to get into areas where D-Star shows its true abilities.

Making the contact

Because you send your call sign in digital form in every transmission, the D-Star network “knows where you are” - or at least the repeater you last used. This information is stored throughout the whole network and is available through the D-Star web sites. (I won't go into this here - but I recommend that you have a look at www.dstarusers.org sometime).

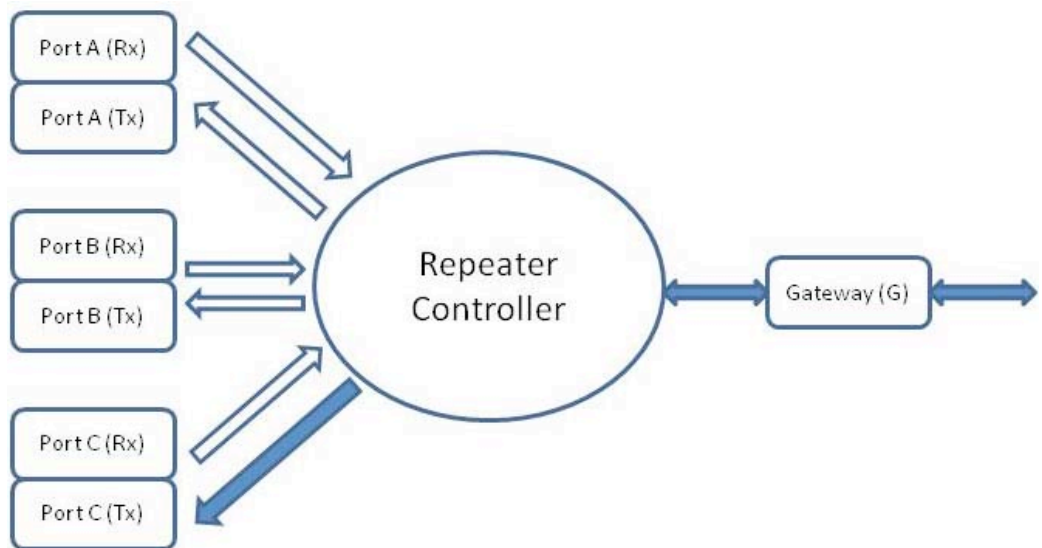

Let's say I (VK3ANZ) want to talk to AA0BBB. I know they have a D-Star radio, which they have taken with them on their holidays. They could be anywhere!

Firstly I need to tell my local repeater that I want to be able to connect to another repeater somewhere else in the network. I do this by setting my Repeater2 call sign to the local repeater gateway - that's the local repeater's call sign that ends in G. This tells the repeater that it is to route my transmission from the incoming repeater port (Repeater1 - that's the one I will be transmitting and listening on) through the D-Star to somewhere else.

In this situation we would set the Destination field on my radio to "AA0BBB"¹⁴.

Call Sign Field	Example Entry
Originator	VK3ANZ
Repeater1	VK3RWN△C
Repeater2	VK3RWN△G
Destination	AA0BBB

With this configuration set, I can send out a call:

"This is VK3ANZ on VK3RWN Port C calling AA0BBB using call sign routing"

So who is listening to that!

Well, as soon as I press the PTT button, I send out the 4 call sign fields to the local repeater. It sees the Destination call sign and does a lookup to see where that call sign was last used. The local repeater will then send my transmission through the network to

¹⁴ Please see the "Usage Issues section below regarding use any call sign registered by a person.

that remote repeater port. (Of course it also transmits my signal back out through the same repeater port I'm using).

That's it.

Answering a contact

This is the same as before (and always really!). Lets assume that I (AA0BBB in this example) have been using the GB0ZZZ repeater recently and I hear someone calling me.

The person making the call has provided me with the necessary information in 2 ways. Firstly, they have told me who they are and where they are calling from. I can then set up my radio using the necessary information. Repeater1 will be the port of the local repeater I will be transmitting to. Repeater2 will be the gateway port of the same repeater (**not** the repeater the other person is using). I can put their call sign (or the call sign of the repeater port they are using - more on this in the next section) into the Destination call sign field of my radio.

Alternatively, I can use the information that the D-Star network will have sent me when I received their call. It will have sent me the caller's call sign and the necessary repeater setting so I can call them back. Most radios have a button that can automatically transfer this information into the appropriate call sign fields.

Call Sign Field	Example Entry
Originator	AA0BBB
Repeater1	GB0ZZZ△A
Repeater2	GB0ZZZ△G
Destination	VK3ANZ or /VK3RWNC

Then I just hit the PTT and reply. The network will use the same process described above in 'Making the contact' to use call sign routing (or repeater routing - see below) of my transmission back to the original caller.

Both radios are now set up and so the QSO can continue.

Finishing the contact

Again I hope you can see why the Usage Guidelines section refers to resetting your radio after you have finished your QSO. In this scenario, I could have been talking through the D-Star network to anywhere in the world. If I don't reset my radio, my next transmission will also be routed through the D-Star network to whichever repeater the other party last used. This means that they will be blessed with my side of some conversation, possibly cutting across other users of that repeater.

The simplest way to avoid this is to set the Destination field call sign to "CQCQCQ". Most commercial radios have a button that will do this for you.

The “CQCQCQ” call sign is treated as ‘special’ by the repeater and will not be used for call sign routing, even if you still have Repeater2 set to the local repeater gateway. After all, where would it send your transmission!

Usage Issues

The comments made previously about needing to check the status information that the local repeater sends back to you after each transmission apply here as well. In this case there are more links in the chain where the transmission can fail.

This also brings up why you need to leave a 4 second pause between overs, apart from being a good repeater user and allowing others time to break in.

The D-Star network needs to do a lot of house-keeping for each transmission. Also it needs time to lookup call signs for call sign routing, establish its own internet connections and then start sending the data packets (that’s what your voice has become, remember) to the remote repeater. This takes time, and it also takes time for the system to clean up after each transmission.¹⁵

There could be a delay of up to several seconds between you speaking your words of wisdom into your microphone before they are broadcast by the remote repeater. If the person on the other end replies almost immediately and there is the same delay, it could be several seconds before you begin to hear their response. If you jump in before that with “QSL???” then all you will do is block their response (remember the repeaters are half-duplex and will only accept a single transmission - from any source - at a time).

Use the time to gather your thoughts so that what you have to say is really thoughtful and profound!

In the “making the contact” section above, I put in the call sign of the person I wanted to talk with. However, earlier on I mentioned that everyone can register up to 8 call signs with the D-Star network, one with just their call sign, and others with a letter in the 8th position to indicate if they were mobile, portable, using a dongle etc.. So, which call sign should I use to contact someone?

The D-Star network remembers the last repeater that each **separate** call sign accessed. Say I use my VK3ANZ call sign in Melbourne and then fly to Sydney where, to show that I’m ‘portable’ I use my “VK3ANZ△P” call sign which I have also registered on the D-Star network. If someone uses call sign routing to contact me, and they use my VK3ANZ call sign, then the signal will be routed to the Melbourne repeater that I last use, even though I used the Sydney repeater more recently. The problem is that I used the “VK3ANZ△P” call sign in Sydney - to have the transmission routed to Sydney, the other person would have had to know that I had used the “VK3ANZ△P” variant of my call sign there , and set that into their Destination call sign field.

To avoid this, the general recommendation is to always use the same (base) call sign in the Originator field of any D-Star radio you use, unless you specifically want the variant call sign to be recognised elsewhere.

¹⁵ This may be a bit simplistic, but going deeper into details would only cloud and not clarify the issue.

Repeater Routing

Let's say I want to talk to anyone who is on a specific repeater port (but not on the same repeater I'm are using). This is very similar to the case above, except that I don't need to know a person's call sign, but rather that of a remote repeater port¹⁶.

Making the contact

I will need to set up my radio to have the call sign of the port I will be entering the local repeater on in the Repeater1 call sign field. I also need to set the local repeater's gateway port call sign in Repeater2.

You should now see an emerging pattern: you can generally set the Repeater1 call sign to the local repeater port when you start using the repeater, and almost always leave Repeater2 set to the gateway port of the local repeater.

OK, so how do I specify the destination repeater I want to access? That's what the Destination call sign is for, but there is a slight twist in this case. When I wanted to talk to a specific person, I just put their call sign into this field. When I want to refer to a repeater port, I use the repeater ports call sign but prefixed with a slash ("/") character: VK5RWN Port B would be entered as "/VK5RWNB". Note that the slash character counts towards the overall 8 character requirement for a call sign and so there is no space between the repeater call sign and the port letter in this case. Of course, if the repeater was XX2AB Port C then I would need to enter "/XX2AB△C".

Call Sign Field	Example Entry
Originator	VK3ANZ
Repeater1	VK3RWN△C
Repeater2	VK3RWN△G
Destination	/VK5RWNB

As always, I then need to tell the listeners who I am, where I'm calling from and to, as in:

"This is VK3ANZ on VK3RWN Port C calling CQ on VK5RWN Port B"

Answering a contact

If I hear a call such as the one in the previous section and I want to respond, I need to set my radio up appropriately. Again this should becoming very familiar to you by now as it is really the same as above¹⁷.

¹⁶ I'm assuming here that the other repeater port is **not** on my local repeater - if it were then this is a 'single band' or 'cross band' situation and covered in the preceding sections.

¹⁷ I did say that there were repetitions in this document, but it also shows how responding to a call is almost identical in all situations.

Most commercial radios have a button I can press that will use the received call sign data of the last (and with some, previous) call my radio received to set up it up correctly so I can answer.

If I want to do this manually, then I set the Repeater1 and Repeater2 values to be the local repeater port call sign I will be transmitting to and the local repeater's gateway call sign respectively. Nothing new there and I may not have to make any adjustments at all.

The Destination call sign field needs to be set up so that my transmission back to the caller will be routed through the network to the correct repeater port. Therefore I can either set the caller's call sign (which is what pushing the button does) or I can use the caller's repeater port call sign with the slash prefix.

Call Sign Field	Example Entry
Originator	VK5SSS
Repeater1	VK5RWN△B
Repeater2	VK5RWN△G
Destination	VK3ANZ or /VK3RWNC

The end result is that my transmission will then be routed back through the D-Star network to the caller's repeater port and broadcast there. From then on we can both carry on our conversation, taking into account the necessary breaks between overs.

Finishing the contact

Does this really need to be said by now? Simply set the Destination call sign field of your radio to "CQCQCQ" so that any further transmissions will not be routed through the network to somewhere else.

Usage Issues

There is nothing really new here apart from the "/" prefix to specify repeater routing. Remember that each transmission you make will be separately routed through the D-Star network. This involves not only the normal transmission delays between repeaters, but also the time required to look up the call sign of the remote repeater port. Then there is the time for the system to determine how to make the connection to that repeater.

Because you are trying to access a repeater that could be anywhere in the world, you are not able to check that the remote repeater port is in use before you transmit. You will recall from section 1 that the controller in each repeater will only allow one connection to an RF ports transmitter at a time. Therefore it is possible for your signal to get all the way to the remote repeater only to find that the repeater port is in use and your whole transmission¹⁸ will be dropped.

¹⁸ The access conflict is detected as soon as the second stream is seen by the repeater's controller. However, once it has detected the conflict and rejected the subsequent connections, even if the first connection finishes while the subsequent streams continue to be received, they will **not** be accepted. Once a data stream is rejected, it is rejected completely.

When a repeater controller rejects a transmission, it will send back a status report to the originating repeater which will, in turn pass this on to you when you finish transmitting. If the transmission got through OK, the status report will refer to your local repeater. However if it was rejected anywhere along the line, the status report will refer to the rejecting repeater.

The status report is sent as a short message that is displayed on the screen of your radio. You should always check the status message after each transmission as this will tell you if you got through to your intended destination or not. (Of course, if you 'doubled' with someone else on the RF repeater input frequency or were otherwise not received by the local repeater, then you will not get a status message back - itself an indication that your transmission was not received correctly).

Different radios display the status message slightly differently, but the following are some of the responses you can get:

Result	ID-1	ID-800	IC-91AD	IC2820
Message transmitted OK	UR? {CS1}	UR? {CS1}	UR? {CS1}	UR? {CS1}
Target station not accessible	UR? {CS2}	UR? {CS2}	UR? {CS2}	CR? {CS2}
Linked repeater not known	RPT?	UR*	UR*	
Report repeater port busy	RPT UP	UR? {CS2}	UR? {CS2}	

where "{CS1}" is the same call sign as you had set in your Repeater1 call sign field, and "{CS2}" will be a call sign of the repeater port where the data stream was rejected.

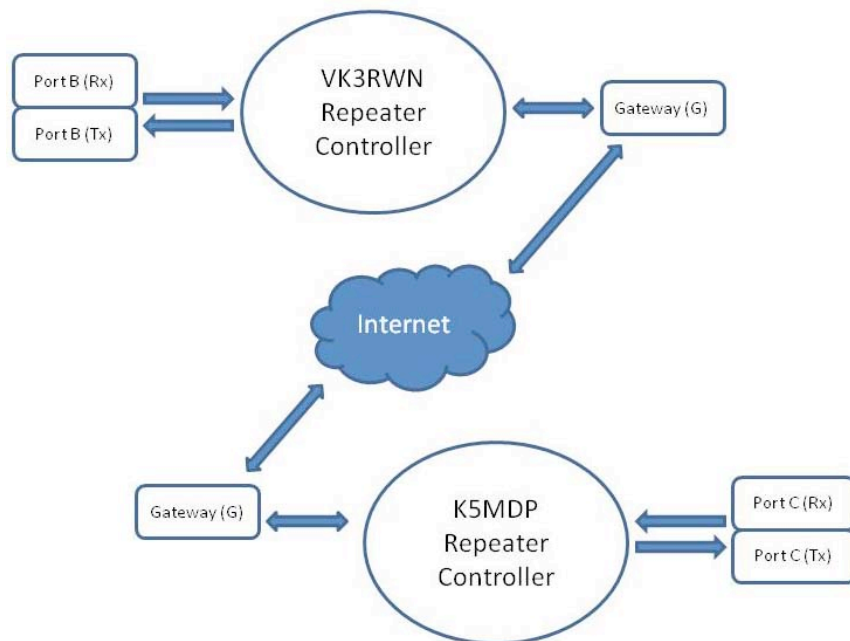

The way the status message is formed is a little unusual in that it generally tells you at what point the transmission **failed**. If the local repeater port didn't get your transmission at all, then you won't get back a status message at all. Once the local repeater port has received your transmission, it will always pass it further down the line. This means that your local repeater port is **not** a possible point of failure of your received transmission, but everywhere else is. The D-Star system therefore uses your local repeater port call sign as its way of signaling success.

Take the situation where shown above where I am using VK3RWN port B to call someone on K5MDP port C. If my transmission gets through to the far end and is transmitted on the report port, then the status I receive will be "UR? VK3RWN B".

However, the transmission could be blocked at several places along the path: at the VK3RWN gateway, at the K5MDP gateway and at K5MDP port C. Let's say the Port C on K5MDP is in use, then I would receive a status of "UR? K5MDP C" which means that the port was the point of failure.

Finally, to flog that poor dead horse some more, it is important that you reset the Destination call sign field to "CQCQCQ" when you have finished your QSO. If you don't, then any future transmissions will be routed through the network and pop up at the remote repeater location. This means that they will be hearing one side (yours) of your next conversation and will just be annoying to them. (If you don't believe me, just wait until someone does it by mistake to your local repeater and keeps breaking in to a QSO you are trying to have with someone else!!!!)

Repeater Linking

You might hear about "Repeater Linking" but I only want to make a few brief remarks.

Until now, all of the ways we have discussed of routing your transmission from one repeater port to another have been on a transmission-by-transmission basis. When you press the PTT button, the connection is established and then removed when you stop transmitting.

Repeater Linking is a way to have two repeater¹⁹ ports connected together until you (or someone else) unlinks them. In this way it is very similar to the way analog repeaters can be connected together: a transmission received by any one is re-broadcast by all of the other linked repeaters. This means that you only need to have your radio set up refer to your local repeater - the linking takes care of the rest.

Repeater linking can be set up on an ad-hoc basis by a user (on either repeater) or it can be set up automatically at predefined days and times by the repeater gateways. (The computer that manages the gateway can be programmed to establish links by the repeater administrator. This can be useful for regular nets or other "official" uses of the repeater)

An important distinction between 'routing' (as covered by the previous sections) and 'linking' is that routing is performed for the duration of each transmission and is designed for individual users to contact other people. Everyone who wants to participate in a conversation must set up their radios correctly.

¹⁹ Of course these are ports on different repeaters!

On the other hand, linking impacts on all users of both of the linked repeater ports. Without anyone needing to do more than gain access to their local linked repeater port, their transmission is automatically carried to the linked remote repeater port. The flip side is that linking affects all users of both repeater ports, and linking ports at inappropriate times can interrupt important communications. (The trouble is that you are never quite sure when it is 'inappropriate'!)

I won't go into the details of how to link repeaters here as the details are available on a number of web sites²⁰ and I believe that repeater linking should not be done indiscriminately.

Reflectors

You can think of a D-Star reflector as a repeater that has no RF ports but has very good internet connectivity. Normally repeaters are located on hills and other places where it is not always convenient to have high-speed Internet access, but they do provide good RF coverage. On the other hand reflectors can exist anywhere that has very good network connectivity and bandwidth and so are usually located in large data centres.

The large bandwidth means that reflectors are able to maintain on-going Internet connections with many repeaters, whereas a repeater can only maintain connections with 1 or 2 other repeaters on an ad-hoc basis. This makes reflectors a very good hub for connecting multiple repeater ports (and DV Dongle users) together.

Reflectors have multiple ports, usually called "A", "B" and "C" following the same pattern as for repeaters.

You can link to a reflector port in the same way as you link to a repeater port. Generally you link to a reflector port with the same name as the repeater port you are linking from. For example, I might link from repeater VK3RWN port C to reflector REF003 port C.

Using a linked repeater or reflector

As far as a general D-Star user is concerned, neither repeater linking nor reflector usage requires any special configuration or knowledge other than how to establish and terminate the link - once the link is established, then any signal picked up by a linked RF port will be sent through to the linked repeater/reflector²¹. However it helps to be aware that the linkages exist²² and that the reflectors are in use so that you know the area of coverage of any transmission, and also how to respond to any call you may hear.

Basically to use as linked repeater, you only need to set your Repeater1 call sign to the local repeater port you are transmitting to, and your Repeater2 to your local repeater's gateway port. Even messages transmitted with "CQCQCQ" in the Destination field will be passed on to the linked repeater/reflector.

²⁰ Basically it involves putting the repeater port in the 7th position of the Destination call sign, and an "L" into the 8th position to establish a link, and putting a "U" into the 8th character position with 7 leading spaces to unlink a repeater

²¹ Remember, reflector ports can have multiple links and to connect many repeater ports anywhere in the world.

²² And this is why linked reflectors have automated announcements every so often.

Call Sign Field	Example Entry
Originator	VK3ANZ
Repeater1	VK3RWN△C
Repeater2	VK3RWN△G
Destination	CQCQCQ

Have a look on the Internet for the correct commands (all entered through the Destination field) to establishing and closing the links from a repeater to other repeaters and reflectors.

There is one very important consideration in using call sign routing on a repeater that is linked - the local repeater will generate 2 separate data streams with one going to the remote repeater where the call sign was last heard and the other going to the linked repeater. With the current software configuration in the repeater controller, there is no check to see if the 2 data streams are going to the same repeater. If they are not, then there is no issue. However if they are, then the result is likely to be a conflict with the possibility that neither will get through. This situation may be addressed in the future but it remains for now.

DV Dongles

Digital Voice (DV) Dongles are devices that you connect to a computer that provide the voice encoding/decoding that occurs within your D-Star radio. The computer also needs to be connected to the Internet so that it can make a network connection to a reflector²³. In this way, dongle users appear to the reflector (or repeater) like any other D-Star connection.

An advantage of a DV Dongle is that the user only needs an Internet connection (with reasonable broadband access - dialup connections are too slow) to get into the D-Star network, even if they are out of range of an RF repeater.

A down side is that DV Dongles lose some of the call sign routing and other features because the software does not allow you to specify anything in the Destination call sign field. This means that dongle users can talk with anyone who uses a reflector (and any connected repeaters) but they cannot initiate links or routes to other repeaters.

When you buy a DV Dongle, you get instructions and web links to the software needed to set up a computer and use the D-Star network using a dongle.

²³ Dongles can also connect to a repeater but this makes unnecessary demands on the repeaters network bandwidth and is discouraged.

Appendix 1 - Your Call, My Call etc. as used by various radios

All of the 'commands' that you need to use to access the power of the D-Star network are contained in 4 call sign fields that throughout this booklet I have referred to as Originator, Destination, Repeater1 and Repeater2.

The various commercial transceivers that are available use different abbreviations for these fields, partly due to the physical size and layout of their various screens, but also as experience has been gained in the 'ease of use' features.

Although the abbreviations should be fairly obvious, the following table will help you relate the common terms used here with the actual fields on your radio.

Radio	Originator	Repeater1	Repeater2	Destination
Icom ID-1	MyCall	Rpt1	Rpt2	UR
Icom ID-800H	MyCall	Rpt1	Rpt2	UR
Icom 2200H	MYC	R1C	R2C	YUC
Icom 2820H	MY	RPT1	RPT2	YOUR
Icom 91AD/92AD	MY	R1	R2	UR
Icom ID880H	MY	RPT1	RPT2	UR
Icom IC-80AD	MY	RPT1	RPT2	UR

Appendix 2 - Additional D-Star radio features

When I got my first D-Star rig, I read the manual. Yes - I'm one of the strange ones who do that. While it is an essential thing to, in some ways it was a bit of a mistake. The manual told me *everything* about the radio, including all of the capabilities that are only used in special circumstances.

Worse, it tried to warn me too much that using a D-Star radio was not the same as using any other analog rig.

For example, when talking about the squelch, it says "One of the differences is in digital mode the squelch does not function as in FM mode. It only activates for digital squelch functions such as CSQL (Digital code squelch) or DSQL (Digital call sign squelch)" This made me think that I had to use one of these in order to be able to receive anything - otherwise the squelch would stay shut.

I was wrong!²⁴

I'm not going to discuss how all of the various additional features of D-Star radios work and how they are used. Rather this short appendix is here to let you know that, while all of the extra features such as EMR communications, digital call sign and code squelch, GPS, voice recording and automatic playback and digital data transfers are all available (on various radios) they are **not** needed for normal operation of D-Star.

Once you have learned the basics as outlined in the main part of this booklet, then you will be in a better position to start to use the additional features. Until then, you will be able to use the D-Star voice communications and get a lot out of your rig.

²⁴ Please note this statement - you won't hear it very often!!!!

Appendix 3 - Other Comments

Simplex use

Simplex operation is also possible, mainly by ignoring all of the rest of this booklet and its talk of the Destination and Repeater1 fields etc..

Using a D-Star radio in simplex mode is much like using any (analog) radio in simplex: agree on the frequency, line up the antenna (if necessary), push the button and talk.

There is none of this “4 seconds between overs” protocol, because there is no network in between that requires the delay.

Signal clarity (R2D2 effect)

One issue that may arise is what is sometimes referred to as “R2D2”. When receiving an analog signal, you might get hiss, crackles and other interference, but unless conditions are fairly bad, you can often get the overall message, even if some words are missing. With digital radio, it is far more important that all of the digital information is received so that the ‘digital to analog’ conversion will be accurate.

Just as FM gets around the interference that AM and SSB signals suffer from, by ignoring the amplitude of the signal and using its shifting frequency, so the digital modulation of a signal overcomes some of the problems with FM. However, the price that is paid is that all of the signal transitions must be accurately received or the reconstructed version of the digital value will not be the same one that originally sent.

The digital values that are transmitted are encoded which is one of the reasons why D-Star has such a narrow bandwidth. The decoding process (back to the original numeric data stream) relies on receiving accurate information so that it can restore the original data; any missed data signal transition will result in bad data being received.

This ‘bad data’ will still be decoded by the receiver as though it were accurate and the resulting audio will be output from the rig, usually resulting in strange sounds that are a bit like the noises of the R2D2 character in the Star Wars movies.

This is also an issue when using repeaters, and is the reason why repeaters are normally situated on a site with good all-round coverage.²⁵

The solution is to make sure that the signals into the receiving antenna are strong enough for there to be few (if any) bit-level errors. When operating in simplex mode this may mean using directional aerials on rotators so as to get the best signal.

However, once you have reliable digital communication established between two stations, then the narrow bandwidth of the D-Star signal and the data-based nature of the modulation means that you are able to pass any information that can be digitally encoded.

²⁵ Some experiments have shown that the digital signal can be successfully used over a greater distance than an FM signal. However, whereas the FM signal gradually degrades with increasing distance, the digital signal either works or it doesn't.

Multicasting

There is also something similar to repeater routing called Multicasting which allows you to route your transmission to a pre-defined group of repeaters. The key word there is 'pre-defined' - the group must be set up by a D-Star administrator and list all of the repeaters in the group.

However, once the group is set up, it is given a name that can be accessed in much the same way as repeater routing - by prefixing the multicast group name with a slash (e.g. for a hypothetical multicast group called "VKWIA", you would put "/VKWIA" into the Destination call sign field.

Before you use this feature, you need to get onto the Internet and find out what multicast groups have been set up and which are appropriate for your use.

Echo test transmission

This process is very useful when you are attempting to reach a repeater, especially when you are mobile or not sure of the reception characteristics from your location. You will be able to hear back if there is any corruption in the data stream (which shows up as the 'R2D2' sounds in the resulting audio).

You request that the repeater port record your transmission and then echo it back to you by putting the repeater call sign into the Destination call sign field with the 8th position being an "E".

For example, to get an echo from port C of the VK3RWN repeater, you would set up the Repeater1 and Repeater2 fields as described in the "Local Repeater, Same band" section and put "VK3RWN△E" in the Destination field.

You then press the PTT button and make a short announcement such as:

"This is VK3ANZ making an echo test of the VK3RWN repeater on Port C"

When you release the PTT button, you will then receive your voice message back again.

Using the echo test facility of a repeater that is linked does **not** result in your test transmission being passed any further than the local RF port.

Appendix 4 - D-Star Data

D-Star works by converting your voice into a digital data stream which is then transmitted by the radio. This data stream can be received by repeaters, transferred through the D-Star network and generally moved all around the place until it is finally transmitted to another radio where the digital data stream is converted back into analog form and fed to a speaker. (This is fundamentally the same for DV Dongles but without the RF aspects).

Therefore it should come as no surprise that it is possible to insert any other form of digital data into the overall data stream and have this passed around the network as well.

D-Star operates on 3 RF bands: 2 meters (C), 70 centimeters (B) and 23 centimeters (A). The RF spectrum needed by the D-Star **digital voice** protocol is fairly narrow; much narrower than for a comparable FM signal²⁶. The narrowness of the bandwidth limits the speed at which data can be exchanged.

Basically this means that the digital data capabilities of D-Star DV system are about the same as those of an SMS message - short bursts of data.

Have a look at software products such as D-RATS which take advantage of the D-Star 'digital data' capabilities and open up a new 'layer' of involvement possible with the D-Star protocol.

Please note that there are often local restrictions and guidelines as to which repeater ports and modes can be used for digital data. Please make yourself aware of these restrictions and guidelines before you start your data transmissions.

However, remember that - just like a voice transmission over RF - the digital data that is transferred can be seen and interpreted by anyone with a correctly configured radio and computer. Unlike your Internet and other network connections to your computer, the data that is transferred over D-Star is not private.

By contrast, the **DD fast data** service offered in the 23cm band has much wider bandwidth and so can accommodate faster data connections. It is realistic to connect a computer and, with the appropriate cables, connections and software, you can transfer web pages from servers within the D-Star network at about dial-up speeds. (Note: most repeaters that offer this level of service have a separate 23cm band repeater port dedicated to digital data. Often the digital data repeater port carries the "A" designation but is on a different frequency to the 23cm digital voice port).

(Short aside: When you put the ability to transfer web pages together with the use of the Internet to connect the D-Star repeaters and reflectors together, the common misconception is that you can access the Internet via D-Star. This is **not** the case. The internet is **only** used as a transport infrastructure. It is possible for a D-Star to Internet gateway to be established but this is not done in Australia because it would breach the Australian Telecommunications Act).

²⁶ D-Star digital voice and low speed digital data use a bandwidth of 6.25 kHz regardless of the RF band being used.

Appendix 5 - GPS, Beacons and other D-Star features

Some D-Star radios have integrated GPS capabilities, and others can have a GPS unit plugged into them (provided the information is transferred in the required format).

This means that your geographical location can be broadcast every so often to the repeater that your radio is currently tuned to. The location information can be recorded in a world-wide database which is available to anyone with an Internet connection so that they can plot your position.

Some radios also have the ability to receive the GPS data from other D-Star radios and so calculate and display the relative direction and distance between them. This is particularly useful on those radios that can also store the geographical location of repeaters and so notify you when you are approaching one when you are mobile.

I don't want to say much more about the GPS capabilities (and possibilities) of D-Star other than this warning: Please don't allow your D-Star radio to transmit your GPS position too often - a process known as 'beaconing'.

Just as with any other D-Star transmission that is processed by a repeater, the repeater controller can only handle 1 data stream at a time on each RF port. Because your beacon transmission is automatic, your radio does not 'listen' first to make sure the repeater port frequency is not being used - it simply makes the transmission.

This can interfere with other signals in 2 ways. It can "double" with another caller and the data streams can interfere. The end result is that the other callers data stream will become corrupted and their signal will be lost.

The second way it can interfere is that the repeater will reject any other data stream that arrives while the beacon information is being received. While this beacon data is only a very short burst, it can still be enough to block a voice transmission that is part of an on-going QSO.

The recommended period of GPS beaconing transmission is once every 30 minutes for stationary radios, and once every 10 minutes for mobile use.

Some radios can be set to transmit their GPS coordinates at the start of each over. This can provide a 'best of both worlds' situation in that you broadcast your position only when you are actively using the D-Star network. Others can see where you are but you are not generating a lot of unintended transmissions.

GPS data can be passed between radios using simplex with each radio being responsible for interpreting the information that is sent.

You may hear the terms APRS and DPRS being used in connection with D-Star and GPS data transfers. APRS uses packet radio to transmit information where the GPS information is normally received by dedicated APRS Digipeaters and fed into the APRS-IS network.

DPRS uses the D-Star low-speed Digital Data component to transmit information across the D-Star network along side voice transmissions. Specialist DPRS Gateway software can be installed on a D-Star gateway which interprets the GPS information and feeds it into the APRS-IS network.