

QUICK REFERENCE

Condition Key	Pressed alone	Pressed while F is pressed	Press and hold and turn the power on
F			reset (with V/M)
MONI	unmutes squelch	keylock/unlock	beep on/off
PTT	transmit		
V/M	VARI. ←→ Memory	Memory Write	Channel Indication Mode
UP	freq./memo. up (scans if pressed a while) (If pressed with PTT, emits alert tone.)	T.O.T.	
DOWN	Freq./memo. down (scans if pressed a while) (If pressed with PTT, emits alert tone.)	tone freq. change	toggles stand-by beep On/Off
CALL	call channel	alarm on/off	alert/Tone Burst
SCAN	scan start with PTT, toggles power Hi/Loa	tone scan start	
LAMP	lamp on/off	Auto Power Off	change lamp mode

ALINCO,INC.

Head Office: "TWIN 21" MID Tower Building 25F
1-61, 2-Chome, Shiromi, Chuo-ku, Osaka 540-8580, Japan
Phone: 06-6946-8150 Fax: 06-6946-8175
E-mail: export@alinco.co.jp

PS0309B

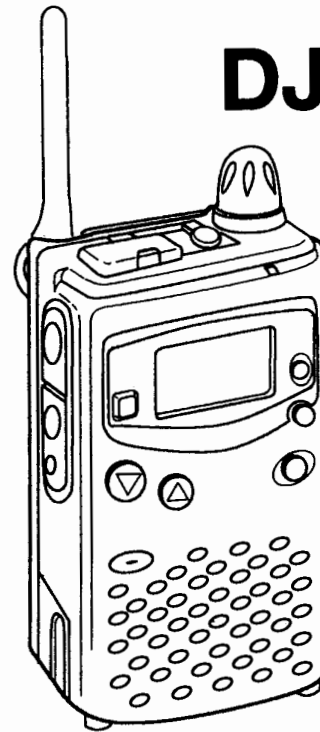
**DJ-SR1****ALINCO,INC.****NOTICES****SAFETY**

- It is material that the user is aware of and understands hazards common to the operation of radio.

LEGAL WARNING

- Government law disallows the operation of unlicensed radio transmitters within the districts under government control.
- Illegal operation is punishable by fine or imprisonment or both.

CAUTIONS

Please observe the following cautions prevent fire, personal injury, and radio damage:

- Refer service to a qualified licensed or certified technician only.
- Turn off and do not operate your radio while taking on fuel, or while parked in gasoline service stations.
- Do not modify this radio for any reason.
- Do not expose the radio to long periods of direct sunlight, nor please the radio close to heating appliances.
- Do not place the radio in excessively dusty areas, humid areas, and wet areas.
- If an abnormal order or smoke is found coming from the radio, switch off the power immediately and remove the batteries from the radio. Contact your ALINCO dealer.

The DJ-SR1 can use all eight allocated frequencies within the PMR446 band, together with 39 possible CTCSS Tone Codes. It is also possible (although not recommended) to switch off (Disable) the Tone Code altogether.

To check a channel for activity, traffic etc, there is a 'moni' button (middle button on side) which will temporarily bypass the squelch and Tone Code and enable reception of any signals on that frequency.

Note that for two or more radios to work with each other, they must all be working on the same frequency (1-8) and Tone Code (A00-C05). Up to twenty memory channels are provided for storing your chosen combinations, and it is recommended that these are used for general communications.



4

1. Setting UP the DJ-SR1

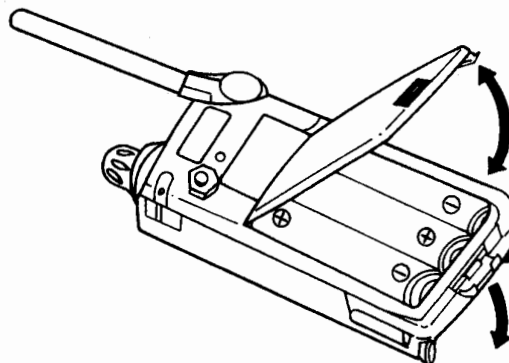

Lift the bottom tab and lift the battery-case cover. Insert EBP-25N Nicad or three R6 (type AA) drycells here. Close, and lock with the bottom tab.



Attach the supplied handstrap.



Attach the supplied belt-clip.

5

2. Description

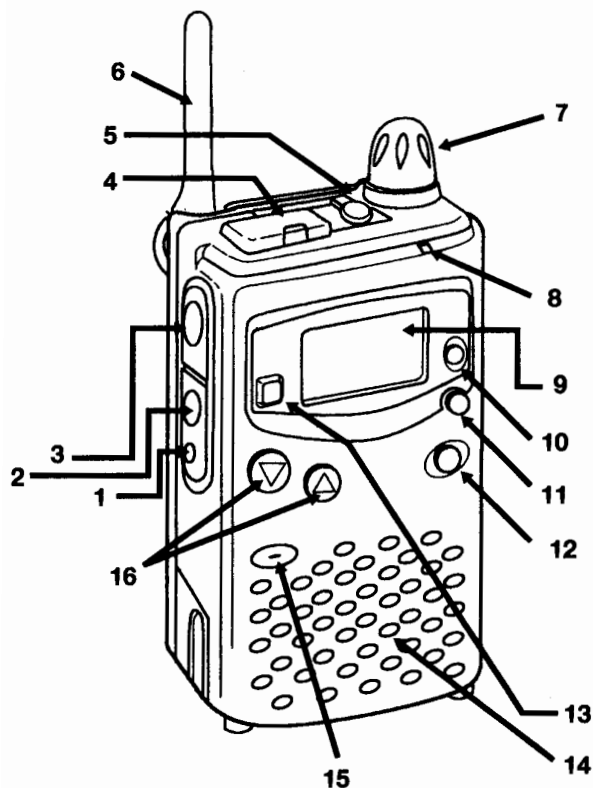

6

1. F (Function)

Press and hold this key and press another key to activate the secondary function.

2. MONI (monitor)

Press this switch to unmute the preset squelch and monitor weak signals. Press and hold the F-key and press this key to lock /unlock the keys to avoid unintended key entries. ("L" is displayed during the keylock.)

3. PTT

Press-to-talk switch.

4. Microphone and Speaker jack

Connect to this jack when using an optional microphone or speaker.

5. External power terminal

Connect the optional EDH-18 or an external regulated 5.5V dc source (negative ground)

CAUTION

Not apply more than 5.5V to the DC socket, and not to apply external voltage when using alkaline batteries.

6. Antenna

Rotate and let the antenna stand up when operating.

7. Power switch and Volume

8. Transmit indicator

This lamp is lit in transmitting.

9. Display

7

10. CALL/BELL

Pressing this key changes your operating frequency to memory ch "C". Pressing again resumes the original frequency. Press and hold the F-key and press this key to turn on/off the alarm function; the function alarms you with an electronic sound when a signal is received (appears in the LCD.)

11. SCAN/T SCAN

Press this key to scan. Press and hold the F-key and press this key to scan CTCSS tone.

12. LAMP/APO

Press this key to illuminate the LCD for 5seconds. Press and hold the F-key and press this key to toggle the APO (auto-power-off); Use the UP/DOWN keys to change the automatic power off timer from OFF to 120min. in 30min. step. Press and hold this key and turn the power on, then the 5second illumination timer is disabled; the lamp is toggled on/off with the key regardless of the time passed.

13. VM/MW

Changes between VFO and memory channel. To program a memory channel, (1) in the Vari. mode, press and hold the F-key and press this key, (2) use the UP/DOWN key to select a memory channel number, (3) Press this key again to memorize the displayed frequency (with tone) to that channel. Memory channels available are : c, 0~19

14. Speaker

15. Microphone

16. UP/DOWN switch

Press this key to change frequency/channel up/downwards.

Press DOWN key while pressing the F-key to enter programming mode for the CTCSS tone. Then press this key to change the encoding tone frequency. Press PTT to exit.

Press UP key while pressing the F-key to enter programming mode for the TOT (Time-Out-Timer); Use the UP/DOWN keys to change the setting time from OFF to 450 seconds.

Pressing the UP/ DOWN key while transmitting will emit tone burst or the alerting ring to raise the attention of the called party. This sound can be toggled between tone burst or the alerting ring by press and hold the call key and turning on the power.

3. DISPLAY

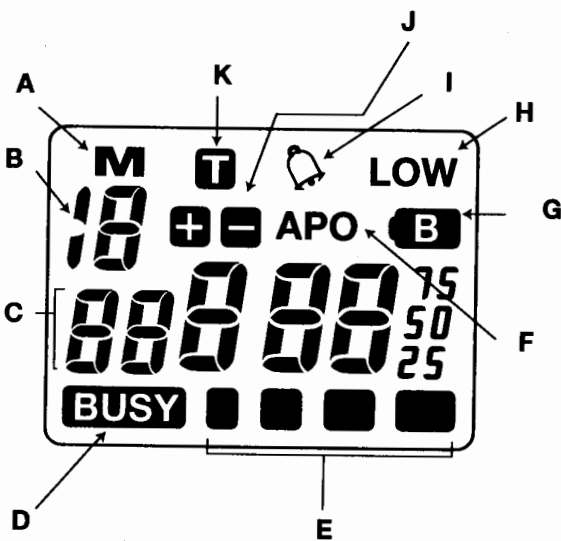

- A: "M" is displayed continuously on a programmed memory channel. The "M" flashes on a memory channel not yet programmed.
- B: Memory channel number
- C: Frequency number and Tone Code (And other parameters when programming functions)
- D: "BUSY" appears upon receiving a signal.
- E: S-meter/RF output power meter.
- F: Auto Power Off enabled
- G: Low Battery Indicator (Flashes when needs replacement or change)
- H: Low Power Output mode indicator
- I: Alarm function on
- J: Not use
- K: CTCSS ON

4. OPERATION

e.g. to program Frequency 3 with tone code A09 into memory CH5

1. Use up/down key until '3' shows at left hand side.
2. Press F + Tone (Tone Code flashes). Use UP/DOWN key until flashing Tone Code at right hand side shows 'A09'.
3. Press PTT once.
4. Press F+V/MMW : Memory channel (flashing M) appears. Use UP/DOWN key until 'M5' appears.
5. Press V/MMW once.

'V/M' key will now toggle between Memory Channel and direct display.

To program further memory channels, press V/M key until Memory channel number disappears, then repeat the above procedure with your own choice of frequency and Tone code; up to twenty memory channels can be programmed in this way.

When at least one memory channel is programmed, it is possible if desired to show Channels only. Switch power off, hold the V/MMW key and switch on again. Repeating this step will restore the frequency/Tone Code screen.

Remember that a pair, or grope, of radios will need to be programmed with identical information in order to 'talk' to each other.

Where a grope of radios are in use, it is useful to have a 'common' readily accessible channel and this facility is provided by the 'CALL' key. Program the group's chosen frequency/Tone Code as above, except at Step

12

channels (or memory contents), and both are set to "scan", pressing the PTT momentarily on one of the radios will cause it to transmit for approx. 5 seconds on whichever channel it happens to be.

The other radio provided it is within operating range, will pause on that channel for a further 5 seconds after receiving this transmission; if the second user presses his PTT to reply within this period, both radios will no longer be in Scan mode, but will remain on the same randomly selected channel to allow conversation; otherwise both users should again press "scan" to start the process again.

If all else fails, or it is required to clear the radio of all programmed information to start again, the radio can be reset. Hold 'F' and 'V/M' and switch on the power, but remember that the radio will then be left 'blank' and will need to be reprogrammed in order to 'talk' with other sets.

CAUTION
ALL PROGRAMMED CHANNELS WILL BE LOST IF THE RADIO IS RESET.

14

four press 'CALL' instead of selecting a Memory channel. Pressing the 'CALL' key will then provide instant access to this channel. If all members of a grope develop the habit of leaving their radios on the 'C' channel, any one radio can call all the others and messages won't be missed. Another channel can then be agreed for a conversation.

N.B. This function does not operate in 'Channel' only mode.

To conserve battery power, if the 'scan' key is pressed while transmitting i.e. PTT is pressed, the radio will switch to LOW power. Note, however, that this will also reduce the communicating distance which can have the advantage of increased privacy at close range.

The 'SCAN' key normally will go through all available frequencies or channels and pause on any active ones it finds. Pressing the key again whilst paused will stop the scan on that channel.

When an active frequency is found, 'F+T Scan' will start a search for the Tone Code in use. Pressing the key again when it pauses will leave the radio set to match the incoming transmission. This is a useful function where the Alinco DJ-SR is required to work with other brands of PMR446 radio where the exact frequencies and/or Tone Codes may not be known.

The result of the SCAN T SCAN procedures can be stored in any memory channel.

The DJ-SR1 also has a simple "channel finder" facility. When two radios are programmed with the same set of

13

5. NUMERICAL ORDER (38 TONES + 1)

1	A00	67.0	21	B07	136.5
2	B00	71.9	22	A08	141.3
3	C01	74.4	23	B08	146.2
4	A01	77.0	24	A09	151.4
5	C02	79.7	25	B09	156.7
6	B01	82.5	26	A10	162.2
7	C03	85.4	27	B10	167.9
8	A02	88.5	28	A11	173.8
9	C04	91.5	29	B11	179.9
10	B02	94.8	30	A12	186.2
11	C05	97.4	31	B12	192.8
12	A03	100.0	32	A13	203.5
13	B03	103.5	33	B13	210.7
14	A04	107.2	34	A14	218.1
15	B04	110.9	35	B14	225.7
16	A05	114.8	36	A15	233.6
17	B05	118.8	37	B15	241.8
18	A06	123.0	38	A16	250.3
19	B06	127.3	39	C00	69.3 *
20	A07	131.8			

15